



AVP, Kotnikova ulica 19a, SI-1000 Ljubljana, tel.: 01 478 8430, vozila@avp-rs.si
STSA, Kotnikova ulica 19a, SI-1000 Ljubljana, tel.: +386 1 478 8430, vozila@avp-rs.si
37141-087/2017/10

**POTRDILO O EU-HOMOLOGACIJI
EU TYPE-APPROVAL CERTIFICATE**

Sporočilo o:
Communication concerning:

- EU-homologaciji
- *EU type-approval*
- ~~razširitvi EU-homologacije~~
- ~~extension of EU type-approval~~
- ~~zavrnitvi EU-homologacije~~
- ~~refusal of EU type-approval~~
- ~~preklicu EU-homologacije~~
- ~~withdrawal of EU type-approval~~

samostojne tehnične enote: naprave za zmanjševanje hrupa
of a type of STU: noise-abatement device

glede na Priloge IX k Delegirani uredbi Komisije (EU) št. 134/2014, kakor je bila nazadnje spremenjena z Delegirano uredbo Komisije (EU) št. 2016/1824
with regard to Annex(es) IX to Commission Delegated Regulation (EU) No 134/2014, as last amended by Commission Delegated Regulation (EU) No 2016/1824

Številka EU-homologacije: **e26*134/2014*2016/1824G*08107*00**
EU type-approval number:

Razlog za razširitev: /
Reason for extension:

**ODDELEK I
SECTION I**

- | | | |
|-------|---|---|
| 0.7 | Znamke (tovarniška imena proizvajalca):
<i>Make(s) (trade name(s) of manufacturer)</i> | AKRAPOVIC |
| 0.8 | Tip:
<i>Type:</i> | M-HCUFG001 |
| 0.8.1 | Trgovska imena (če obstajajo):
<i>Commercial name(s) (if available):</i> | / |
| 0.9 | Ime podjetja in naslov proizvajalca:
<i>Company name and adress of manufacturer:</i> | AKRAPOVIC D.D.
MALO HUDO 8A
1295 IVANCNA GORICA
Slovenia |

-
- 0.9.1. Imena in naslovi proizvodnih tovarn:
Name(s) and address(es) of assembly plant(s): AKRAPOVIC D.D.
MALO HUDO 8A
1295 IVANCNA GORICA
Slovenia
- AKRAPOVIČ D.D., PE ČRNOMELJ
ULICA HEROJA STARIHA 24
8340 ČRNOMELJ
Slovenia
- 0.9.2. Ime in naslov zastopnika
proizvajalca (če obstaja):
*Name and address of manufacturer's
representative (if nay):* /
- 0.10. Pri samostojni tehnični enoti,
vozila, za katere je namenjena:
*In the case of seperate technical unit,
vehicle(s) for which is intended for:* Husqvarna
- 0.10.1 Tip:
Type: HQV 401 (e1*168/2013*00064*)
- 0.10.2 Variante:
Variant(s): vse
all
- 0.10.3 Izvedenke:
Version(s): vse
all
- 0.10.4 Trgovska imena (če obstajajo):
Commercial name(s) (if available): Svartpilen 401
Vitpilen 401
- 0.10.5 Kategorija, podkategorija in
podpodkategorija vozila:
*Category, subcategory and
sub-subcategory of vehicle:* L3e-A2

ODDELEK II
SECTION II

1. Tehnična služba, pristojna za izvajanje preskusov:
Technical service responsible for carrying out the tests: TÜV SÜD Auto Service GmbH
Westendstraße 199
D-80686 München
Germany
2. Datum poročil o preskusu:
Date of test report(s): 27.02.2018
3. Številka poročil o preskusu:
Number of test report(s): 18-00030-CM-GBM-00
4. Opombe:
Remarks: glej Dodatek
see Addendum
- 4a. Homologacija je:
The approval is: **podeljena**
granted
- 4a.1. Homologacija se podeli na podlagi člena 40
Uredbe (EU) št. 168/2013, tako da je njena
veljavnost omejena do: ne pride v poštev
*The approval is granted in accordance with Article
40 of Regulation (EU) No 168/2013 and its
validity is thus limited to:* *not applicable*
5. ~~Omejitve veljavnosti:~~
~~*Restrictions of validity:*~~ /
6. ~~Uporabljene opustitve:~~
~~*Waivers applied:*~~ /
- Kraj:
Place: 1000 LJUBLJANA
- Datum:
Date: 08.03.2018
- Ime in podpis:
Name and signature: mag. Tomaž Svetina, univ. dipl. inž. str.
vodja sektorja za vozila



Temu sporočilu je priložen seznam dokumentov, ki so deponirani pri homologacijskem organu, ki je odobril to homologacijo in jih je na zahtevo mogoče dobiti:

glej kazalo opisne dokumentacije št. e08107 Rev.00

The list of documents deposited with the Administrative Service which has granted approval is annexed to this communication and may be obtained on request:

see index to information package No e08107 Rev.00

Dodatek k potrdilu o EU-homologaciji s številko EU-homologacije:
Addendum to the EU type-approval certificate with EU type-approval number:
e26*134/2014*2016/1824G*08107*00

1. **Omejitve uporabe samostojne tehnične enote: naprave za zmanjševanje hrupa:**
Restriction of use of the STU: noise-abatement device:

glej prilogo 2 testnega poročila 18-00030-CM-GBM-00
see enclosure 2 of the test report 18-00030-CM-GBM-00

2. **Posebni pogoji za vgradnjo samostojne tehnične enote: naprave za zmanjševanje hrupa:**
Special conditions for the mounting of the STU: noise-abatement device:

glej proizvajalčeva navodila za vgradnjo
see manufacturer's instruction manual

3. **Opombe:**
Remarks:

/

Ta homologacija se uporablja za tip serijsko izdelanih neoriginalnih izpušnih sistemov za tip motornega kolesa ali njegovih sestavnih delov pod naslednjimi pogoji:

Posamezni proizvodi iz serijske proizvodnje morajo ustrezati najmanj vsem zahtevam Uredbe (EU) št. 168/2013 in Priloge IX k Delegirani uredbi Komisije (EU) št. 134/2014, nazadnje spremenjene z Delegirano uredbo Komisije (EU) št. 2016/1824, "Zahteve za preskus tipa IX: raven hrupa".

Priloženo poročilo o preskusu in risbe so sestavni del te homologacije.

Vsak sestavni del neoriginalnega izpušnega sistema, vendar ne deli in cevi za vgradnjo, mora biti čitljivo in trajno označen z:

- znamko (tovarniškim imenom proizvajalca),
- trgovskim imenom,
- homologacijsko oznako.

Temu tipu proizvoda se dodeli naslednja homologacijska oznaka:

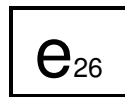

08107G

Homologacijska oznaka na proizvodu mora po izvedbi in velikosti ustrezati zahtevam Izvedbene uredbe Komisije (EU) št. 901/2014, nazadnje spremenjene z Izvedbeno uredbo Komisije (EU) št. 2016/1825.

S tem homologacijskim znakom so lahko označeni samo tisti proizvodi, ki v celoti ustrezajo homologacijski dokumentaciji.

Oznaka EU-homologacije samostojne tehnične enote ali sestavnega dela mora biti na samostojni tehnični enoti ali sestavnem dele nameščena tako, da je neizbrisna (npr. odtisnjena, jedkana, lasersko vgravirana, samouničljiva nalepka), jasno berljiva in vidna na mestu, kjer se namesti na vozilo, ne da bi bilo treba kateri koli del odstraniti z orodjem.

Proizvod je lahko označen tudi s tujo homologacijsko ali drugo oznako, če s tem ni motena razpoznavnost in čitljivost homologacijske oznake, ki jo je dodelil slovenski homologacijski organ.

Na proizvodu ne sme biti oznak, ki bi lahko privedle do zamenjave z uradno dodeljeno oznako.

Kakršnekoli spremembe na proizvodu so dovoljene samo na podlagi posebnega dovoljenja homologacijskega organa.

Veljavnost homologacije preneha z vrnitvijo ali z odvzemom. Homologacija se odvzame, če pogoji za podelitev in obstoj homologacije ne obstajajo več, če lastnik homologacije krši obveznosti, povezane s homologacijo, oziroma če se ugotovi, da homologirani proizvod ne ustreza več veljavnim predpisom.

Proizvajalec je dolžan stalno kontrolirati kakovost homologiranega proizvoda in njegovo skladnost s homologacijsko dokumentacijo. O tej kontroli je dolžan voditi evidenco in omogočiti vpogled v zapiske nadzornemu organu, ki ga določi homologacijski organ. V primeru ugotovitve neskladnosti s homologacijsko dokumentacijo je proizvajalec dolžan o tem takoj obvestiti homologacijski organ.

Homologacijski organ lahko kadarkoli preverja pravilno izvajanje pooblastil, dodeljenih s to homologacijo, in v ta namen tudi izbira vzorce za ponovni preskus. Stroške takšnih pregledov in presoj skladnosti proizvodnje, se zaračunajo proizvajalcu.

Vsako spremembo oznake proizvajalca, naslova ali proizvodne tovarne oziroma pri homologaciji imenovane pooblaščenice je treba takoj sporočiti homologacijskemu organu.

Pravice, podeljene s to homologacijo, so neprenosljive. Pravice tretjih s to homologacijo niso prizadete.

V primerih, da se proizvodnja ali prodaja proizvoda ne začne v roku enega leta od podelitve homologacije, da se proizvodnja ali prodaja prekine za več kot eno leto oziroma, da se predvideva taka prekinitve, je o tem treba takoj obvestiti homologacijski organ.

O začetku proizvodnje ali začetku prodaje oziroma njihovem ponovnem začetku je treba obvestiti homologacijski organ najkasneje v enem mesecu.

Neupoštevanje zgoraj navedenih določil lahko povzroči odvzem homologacije in se kazensko preganja.

Pravno razlago v zvezi s to homologacijo lahko daje samo homologacijski organ.

08.03.2018



mag. Tomaž Svetina, univ. dipl. inž.
vodja sektorja za vozila

This Approval shall apply to non-original exhaust systems for a type of motorcycle or its components from serial production under the following conditions:

Individual products from serial production shall comply at least with all requirements set out in the Regulation (EU) No 168/2013 and Annex(es) IX to Commission Delegated Regulation (EU) No 134/2014, as last amended by Commission Delegated Regulation (EU) No 2016/1824, "Test type IX requirements: sound level".

The attached test report and drawings shall be a constituent part of this Approval.

Each component of the nonoriginal exhaust system, excluding pipes and fitting accessories, shall be marked with a readable and durable:

- *make (trade name of manufacturer),*
- *commercial name,*
- *approval marking.*

This type of product shall be allotted the following approval marking:

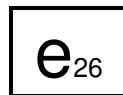

08107G

The design and size of the approval marking shall meet the requirements of the Commission implementing Regulation (EU) No 901/2014, as last amended by Commission implementing Regulation (EU) No 2016/1825.

Only products which comply with the approval documentation may bear the approval marking.

The EU separate technical unit or component type-approval mark shall be affixed to the separate technical unit or component in a way which is indelible (e.g. stamped, etched, laser-engraved, self-destructing adhesive label), clearly legible and visible in the place at which it is to be fitted to the vehicle without the need to remove any parts with the use of tools.

The product may also be marked with a foreign approval or other marking, provided that the identifiability and readability of the approval marking granted by the Slovenian Type Approval Authority is not affected.

The product shall not bear any markings that may lead to confusion with the officially allotted marking.

Changes of any kind performed on the product shall be subject to special permission by the Slovenian Type Approval Authority.

The Approval will become ineffective when returned or withdrawn. The Approval shall be withdrawn: should the conditions for its granting and existence no longer exist, should the owner of the Approval break his obligations related to the Approval, or when it has been established that the approved product no longer complies with the applicable regulations.

The manufacturer shall regularly inspect the quality of the approved product as well as its conformity with the approval documentation. He shall keep record of this inspection and allow to the surveillance body appointed by the Slovenian Type Approval Authority access to the records. Should any non-conformities be found with respect to the approval documentation, the manufacturer shall immediately inform thereof the Slovenian Type Approval Authority.

Any time, the Slovenian Type Approval Authority may check the correct implementation of the authorizations appointed through this Approval, and for this purpose also select samples for a repeated

test. The costs of such checks and conformity of production assessments are charged to the manufacturer.

Any changes regarding the manufacturer's marking, the address or the production plant, or the authorized person appointed through this Approval, shall be forthwith notified to the Slovenian Type Approval Authority.

The rights granted through this Approval shall be untransferrable. The rights of third persons shall not be affected through this Approval.

In the case where the production or sale of the product does not start within one year after the granting of the Approval, or the production or sale is interrupted for a period longer than one year, or such interruption is foreseen, the Slovenian Type Approval Authority shall be immediately notified.

The Slovenian Type Approval Authority shall be notified of the start of production or start of sale, or its restart, within a month's time at the latest.

Non-compliance with above stated provisions may result in withdrawal of the Approval and will be prosecuted.

Legal explanations in relation with this Approval may only be given by the Slovenian Type Approval Authority.

08.03.2018



Tomaž Svetina, M.Sc./Eng.
Head of Vehicle department



KAZALO OPISNE DOKUMENTACIJE e08107
INDEX TO THE INFORMATION PACKAGE e08107

Revision: 00

Homologacijska številka: **e26*134/2014*2016/1824G*08107**
Approval number:

Razširitev številka: **00**
Extension number:

Zgodovina homologacije / Opisne dokumentacije:
Type approval / Information package history:

Razširitev / Revizija: Extension / Revision:	Zadeva: Subject:	Datum izdaje: Date of issue:	Skupno št. strani: Total No. of pages:
00/00	Odobritev homologacije Granting of type approval	08.03.2018	31

Poročilo o preskusu: **18-00030-CM-GBM-00**
Test report:

Število strani: **14**
Number of pages:

datum izdaje: **27.02.2018**
date of issue:

datum zadnje spremembe: /
date of latest amendment:

Opisni list/Tehnični opis naprave: **M-HCUFG001**
Information document/Technical description of the device:

Število strani: **2**
Number of pages:

datum izdaje: **27.02.2018**
date of issue:

datum zadnje spremembe: /
date of latest amendment:

Risba(e)¹:
Drawing(s)¹:

Število strani: **4**
Number of pages:

datum zadnje spremembe: /
date of latest amendment:

Navodila za vgradnjo in uporabo:
Mounting and handling instructions:

Število strani: **10**
Number of pages:

datum zadnje spremembe: /
date of latest amendment:

Ostala dokumentacija:
Other documentation:

Število strani: **1**
Number of pages:



¹ kosovnice, slike, sheme in diagrami / ¹ bill of materials, pictures, schematics and diagrams

**SLOVENIAN TRAFFIC SAFETY AGENCY,
KOTNIKOVA ULICA 19a,
1000 LJUBLJANA,
SLOVENIA**

We, Akrapovič d.d., Malo Hudo 8a. 1295 Ivančna Gorica, Slovenia hereby ask STSA to grant approval against **134/2014*2016/1824 EC (G)** for the following product:
Exhaust system for Motorcycles - muffler:

Type: **M-HCUFG001**

Version: **M-HCUFG001 01SSBL (SS / SS / SS)**
M-HCUFG001 01TBL (SS / Ti / SS)
M-HCUFG001 02SSBL (SS / SS / Ca)
M-HCUFG001 02TBL (SS / Ti / Ca)
M-HCUFG001 05TBL (Ti / Ti / Ca)
M-HCUFG001 06TBL (Ti / Ti / Ti)
M-HCUFG001 01SS (SS / SS / SS)
M-HCUFG001 01T (SS / Ti / SS)
M-HCUFG001 02SS (SS / SS / Ca)
M-HCUFG001 02T (SS / Ti / Ca)
M-HCUFG001 05T (Ti / Ti / Ca)
M-HCUFG001 06T (Ti / Ti / Ti)

Manufacturer: **Akrapovič d.d.**
Malo Hudo 8a
1295 Ivančna Gorica
Slovenia

We declare that we have not applied to any other Approval Authority in the EU Member States for this approval.

We have requested **TÜV SÜD Auto Service GmbH**, to carry out all testing required by the directive and/or regulation that the approval is sought against and to present the entire documentation for the approval.

Yours sincerely,

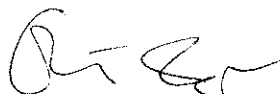
Akrapovič d.d.
Uroš Rosa, CEO

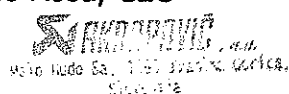
Malo Hudo 8a, 1295 Ivančna Gorica,
Slovenija

Date: 02.10.2017



Techn.Bericht Nr. / *Techn. Report No.*: 18-00030-CM-GBM-00
Hersteller / *Manufacturer*: Akrapovic, Malo Hudo 8a, 1295 Ivančna Gorica, Slovenija

Typ / *Type*: M-HCUFG001

Seite / *Page* 1/7

PRÜFBERICHT TEST REPORT

Nr. / *no.* 18-00030-CM-GBM-00

über die Prüfung zur Bauartgenehmigung einer Nicht-Originalauspuffanlage oder von Einzelteilen hiervon als selbstständige technische Einheit für Krafträder.

about a test regarding a component type-approval for non-original exhaust system or components thereof, as a technical unit for motorcycles

Verordnung / *Regulation* (EU) 134/2014 vom / *dated* 16.12.2013
zuletzt geändert / *last amended* (EU) 2016/1824 vom / *dated* 14.07.2016
Kodierung / *Codification* G

zur Ergänzung der Verordnung (EU) Nr. 168/2013 des Europäischen Parlaments und des Rates.
supplementing Regulation (EU) 168/2013 of the European Parliament and the Council.

Genehmigungsstand / <i>Approval status</i>		
<input checked="" type="checkbox"/>	Erteilung einer Typgenehmigung <i>Granting of a type approval</i>	e26*134/2014*2016/1824G*08107*00
<input type="checkbox"/>	Nachtrag/Änderung zur Typgenehmigung Nr. <i>Extension/correction to type approval no.</i>	

Gründe der Erweiterung / *Reasons for extension*

Es wird geändert: -
It will be changed: -

Es wird aktualisiert: -
It will be updated: -



0. Allgemeine Angaben / *General information*

0.1. Fabrikmarke / *Make*: Akrapovic Exhaust System Technology

0.2. Typ / *Type*: M-HCUFG001

0.2.1. Ausführungen / *Variants*

Ausführungen / <i>Variants</i>	Material / <i>Material</i>		
	Rohre / <i>Tubes</i>	Außenmantel / <i>Sleeve</i>	Endkappe / <i>End cap</i>
M-HCUFG001 01SSBL	VA / <i>Stainless steel</i>	VA / <i>Stainless steel</i>	VA / <i>Stainless steel</i>
M-HCUFG001 01TBL	VA / <i>Stainless steel</i>	Titan / <i>Titanium</i>	VA / <i>Stainless steel</i>
M-HCUFG001 02SSBL	VA / <i>Stainless steel</i>	VA / <i>Stainless steel</i>	Karbon / <i>Carbon</i>
M-HCUFG001 02TBL	VA / <i>Stainless steel</i>	Titan / <i>Titanium</i>	Karbon / <i>Carbon</i>
M-HCUFG001 05TBL	Titan / <i>Titanium</i>	Titan / <i>Titanium</i>	Karbon / <i>Carbon</i>
M-HCUFG001 06TBL	Titan / <i>Titanium</i>	Titan / <i>Titanium</i>	Titan / <i>Titanium</i>
M-HCUFG001 01SS	VA / <i>Stainless steel</i>	VA / <i>Stainless steel</i>	VA / <i>Stainless steel</i>
M-HCUFG001 01T	VA / <i>Stainless steel</i>	Titan / <i>Titanium</i>	VA / <i>Stainless steel</i>
M-HCUFG001 02SS	VA / <i>Stainless steel</i>	VA / <i>Stainless steel</i>	Karbon / <i>Carbon</i>
M-HCUFG001 02T	VA / <i>Stainless steel</i>	Titan / <i>Titanium</i>	Karbon / <i>Carbon</i>
M-HCUFG001 05T	Titan / <i>Titanium</i>	Titan / <i>Titanium</i>	Karbon / <i>Carbon</i>
M-HCUFG001 06T	Titan / <i>Titanium</i>	Titan / <i>Titanium</i>	Titan / <i>Titanium</i>

Die Ausführungen unterscheiden sich in der Verwendung verschiedener Werkstoffe. Der konstruktive Aufbau ist gleich. Das akustische Verhalten ist gleichwertig.

The variants vary because different materials are used. The basic construction remains the same. The acoustic behaviour is similar.

Techn.Bericht Nr. / *Techn. Report No.*: 18-00030-CM-GBM-00
Hersteller / *Manufacturer*: Akrapovic, Malo Hudo 8a, 1295 Ivančna Gorica, Slovenija

Typ / *Type*: M-HCUFG001

Seite / *Page* 3/7

- 0.3. Name und Anschrift des Herstellers /
Name and address of manufacturer: Akrapovic d.d.
Malo Hudo 8a
1295 Ivančna Gorica
Slovenia
- 0.4. Name und Anschrift des Beauftragten /
Name and address of authorized agent: entfällt / *n.a.*
- 0.5. Nr. des Beschreibungsbogens /
No. of information document: M-HCUFG001
Ausgabedatum / *Date*: 27.02.2018
- 1.0. Klasse der Fahrzeuge, für die die
Anlage bestimmt ist / *Class of the
vehicles the unit is used for*: L3e
- 1.1. Beschreibung der Fahrzeuge, für
die die Einrichtung bestimmt ist /
*Description of the vehicles
the unit is used for*: siehe Anlage 2 / *notice enclosure 2*

2. Angaben zum Prüfobjekt / *Composition of the separate technical unit*

- 2.1. Art der Technischen Einheit:
Kind of technical unit: Siehe Anlage Technische Dokumentation
See Enclosure, Technical documentation
- 2.2. Ort der Kennzeichnung/
Place of marking: Lasergravur auf Endkappe / Typschild aufgenietet
Engraved by laser / plate fixed with rivets
- 2.3. Zusammenstellung der technischen Einheit /
*Composition of the separate
technical unit*: siehe Anlage 1 / *notice enclosure 1*
- 2.4. Lage und Richtung der Auspuffmündung:
Position and direction of the tail pipe: rechts seitlich nach hinten
at the right side to the rear
- 2.5. Prüfmuster eingegangen am:
Test samples submitted for testing at: 05.12.2017

Techn.Bericht Nr. / *Techn. Report No.*: 18-00030-CM-GBM-00
Hersteller / *Manufacturer*: Akrapovic, Malo Hudo 8a, 1295 Ivančna Gorica, Slovenija

Typ / *Type*: M-HCUFG001

Seite / *Page* 4/7

3. Prüfprotokoll / *Test report*

Versuchsreihe A / *Tests series A*

3.1. Fahrzeug lfd. Nr. 1) / *Vehicle no. 1)*

- 3.1.1. Typ / *Type*: HQV 401
3.1.1.1 Variante / Version / *Variant / Version*: B1 / -
3.1.1.2 Fahrzeugkategorie / *Category*: L3e-A2
3.1.1.3 Handelsbezeichnung / *Model*: Svartpilen 401
3.1.2. Hersteller / *Manufacturer*: KTM AG
3.1.3. Genehmigungs-Nr. / *Homologation no.*: e1*168/2013*00064*
3.1.3.1 Nachtrag bzw. Erweiterung / *Extension*: 00
3.1.4. Fahrzeugidentifizierungsnummer / *Vehicle identification no.*: VBKUNJ409JM218496
3.1.5. Baujahr / *Year of manufacture*: 2017
3.1.6. km-Stand / *Kilometers*: 39
3.1.7. Zul. Gesamtgewicht / *total weight*: 355 kg

3.2. Antriebsmaschine / *Engine*

- 3.2.1. Hersteller / *Manufacturer*: KTM
3.2.2. Typ / *Type*: 938
3.2.3. Hubraum / *Engine capacity*: 373 cm³
3.2.4. Höchstleistung / *engine net power*: 31 kW bei / *at* 9000 min⁻¹
3.2.5. max. Drehmoment / *net torque*: 37 Nm bei / *at* 6750 min⁻¹

3.3. Kraftübertragung / *Transmission*

- 3.3.1. Art der Kraftübertragung / *Kind of transmission*: mechanisch / *mechanical*
3.3.4. Getriebe / *Gearbox*: manuel / *manual*
3.3.5. Übersetzungsverhältnisse / *Transmission ratios*:
primär / *primary* / sekundär / *secondary* 2,666 / 3,000
Höchstgeschwindigkeit / *Top speed*: 160 km/h
Reifen / *Tires*:
vorne / *front* Pirelli Scorpion Rally 110/70 R17
hinten / *rear* 150/60 R17

3.4. Zusammenbau der Auspuffanlage / *Assembly of the exhaust system*

(Teile lfd. Nr. lt. Anl. 1 /
no. of parts, enclosure 1)

Versuchsreihe A / *Tests series A*: 1)2)3)

Techn.Bericht Nr. / *Techn. Report No.*: 18-00030-CM-GBM-00
Hersteller / *Manufacturer*: Akrapovic, Malo Hudo 8a, 1295 Ivančna Gorica, Slovenija

Typ / *Type*: M-HCUFG001

Seite / *Page* 5/7

3.5. Messung der Geräuschwerte / *Acoustic measurements*

- 3.5.1. Hersteller des Messgerätes /
Manufacturer of the sound level meter: GRASS
- 3.5.2. Typ des Messgerätes /
Type of the sound level meter: F-2003; F-2004; F-2018
- 3.5.3. Fahrgeräusch, Standgeräusch /
Drive by noise, stationary noise:

nach ECE-R 41.04 /
according ECE-R 41.04
- 3.5.4. Beladungszustand bei der Fahrgeräuschmessung /
Load condition during drive by test: Leergewicht zuzüglich 75 kg Fahrer /
Unloaded weight plus 75 kg driver
- 3.5.5. Abweichung bei Kalibrierung /
Deviation at calibration: < 0.2 dB(A)

3.6. Messung der Leistung / *Power measurement*

- 3.6.1. Messung der Leistungskurve mit Nicht-Originalauspuffanlage /
Testing of max. power with non-original exhaust system:

Die gemessene Nennleistung und die zugehörige Drehzahl liegen im Toleranzbereich von 5% im Vergleich zu den mit der Originalauspuffanlage gemessenen Werten. (siehe Anlage) /
The tested max. power and the engine speed are in the 5% tolerance in comparison with the original exhaust system. (see enclosure)
- 3.6.2. Messung der Höchstgeschwindigkeit mit Nicht-Originalauspuffanlage/
Testing of top speed with non-original exhaust system:

Entfällt, da Fahrzeugklasse: L3e
Not applicable, because vehicle class: L3e

3.7. Konditionierung der Auspuffschalldämpferanlage / *Conditioning*

durch Druckschwingungen / *by pulsation*

3.8. Messung der Schadstoffemissionen / *Pollution Test*

Auf eine Messung des Abgasverhaltens konnte verzichtet werden, da der original Katalysator unverändert im Abgassystem verbleibt. Eine Verschlechterung des Abgasverhaltens ist nicht zu erwarten.

The Pollution test was not necessary because the original catalytic converter remains without any changes in the exhaust system. A degradation of catalyst efficiency is not expected.

3.9. Ergebnisse / *Test results*

Die Ergebnisse der Prüfungen hinsichtlich / *The results of*

- 3.9.1. Geräusche / *Noise testing*
- 3.9.2. Leistung / *Power measurement*
- 3.9.3. Höchstgeschwindigkeit / *Top speed*
- 3.9.4. Abgasverhalten / *Pollution test*

sind der als Anlage beigefügten Tabellen zu entnehmen / *are attached in the enclosure.*

Aufgrund der Messung mit dem/n o.g. Fahrzeug/en können auch die in Anlage 2 aufgeführten Kraffräder die die gleiche Serien- Auspuffanlage besitzen und gleiche bzw. geringere Motorleistung haben, mit in den Verwendungsbereich aufgenommen werden/ *All motorcycles with the same serial exhaust system and same or less performance mentioned in enclosure 2, can be taken into the field of application due to the measurement with the above named motorcycle/s.*

- 3.9.5. Die beschriebene Nicht-Originalauspuffanlage / Technische Einheit darf an den in der Anlage 2 aufgeführten Krafffahrzeugen unter den dort genannten Bedingungen verwendet werden. / *The described non-original exhaust system / technical unit is suitable for an application at the vehicles listed in enclosure 2.*
- 3.9.6. Die allgemeinen Spezifikationen gemäß (EU)134/2014; Anhang IX; Anlage 2; Abschnitt 3.5.1. werden durch die Nicht-Originalauspuffanlage als technische Einheit erfüllt. / *The general specifications regarding (EU)134/2014; Annex IX; Appendix 2; Clause 3.5.1. are fulfilled by the non-original exhaust system as technical unit.*

4. Anlagen / *Enclosures*

Anlage 1, Teile der Nicht-Originalauspuffanlage
Enclosure 1, Composition of the non original exhaust system
Anlage 2, Verwendungsbereich
Enclosure 2, Field of application
Anlage 3, Ergebnis der Prüfungen
Enclosure 3, Test results
Anlage, Leistungskurve
Enclosure, Performance diagram
Anlage, Protokoll Geräuschmessung
Enclosure, protocol noise test
Beschreibungsbogen
Information Document

5. Schlussbescheinigung / *Summary*

Der angegebene Beschreibungsbogen und der darin beschriebene Typ entsprechen der genannten Prüfgrundlage. Der ungünstigste Fall wurde entsprechend Prozessbeschreibung „Erstellung von Gutachten“ bestimmt.

Der Prüfbericht darf nur vom Auftraggeber und nur in vollem Wortlaut vervielfältigt und weitergegeben werden. Eine auszugsweise Vervielfältigung und Veröffentlichung des Prüfberichtes ist nur nach schriftlicher Genehmigung des Prüflaboratoriums zulässig
The information folder and the type described therein are in compliance with the test specification mentioned above. The worst-case was selected in accordance with document "Preparation of Test Reports".

The test report may be reproduced and published in full and by the client only. It can be reproduced partially with the written permission of the test laboratory only.

Genehmigungsbehörde / <i>Approval authority</i>	Land / <i>Country</i>	Registriernummer / <i>Registration-number</i>	Aktueller Benennungsumfang / <i>Actual scope list</i>
Kraftfahrt-Bundesamt (KBA)	Deutschland/ <i>Germany</i>	KBA-P 00100-10	www.kba.de
Vehicle Certification Agency (VCA)	Vereintes Königreich/ <i>United Kingdom</i>	VCA-TS-006	http://ec.europa.eu/enterprise/sectors/automotive/approval-authorities-technical-services/technical-services/index_en.htm
Approval Authority of the Netherlands (RDW)	Niederlande/ <i>The Netherlands</i>	RDWT-082-01	
National Standards Authority of Ireland (NSAI)	Irland/ <i>Ireland</i>	Technical Service Number: 49	
Vehicle Safety Certification Center (VSCC)	Taiwan/ <i>Taiwan</i>	DE04-06-2	http://www.vsc.org.tw/English/Default.aspx

München, 27.02.2018



Dipl.-Ing. (FH) Max Höhler
Prüfingenieur / *The Expert*



ANLAGE 1
ENCLOSURE 1

zum Prüfbericht Nr. / to test report no.
Typ / Type:
Hersteller / Manufacturer:

18-00030-CM-GBM-00
M-HCUFG001
Akrapovic, Malo Hudo 8a
1295 Ivančna Gorica, Slovenija

Teile der Nicht-Originalauspuffanlage + Originalteile/
Composition of the original exhaust system + original parts

Seite / Page 1/1

Lfd. Nr. / No.	Einzelteile, Abmessungen in mm / <i>Components parts, dimensions in mm</i>	Abmessungen des Teiles in mm bzw. Originalteil / Ersatzteil / <i>Dimensions of the part in mm or original part / replacement part</i>	Teilenummer bzw. Genehmigungsnummer / <i>Part no. or homologation no.</i>
1)	Krümmerröhr, / <i>header pipes</i>	Originalteile / <i>original parts</i>	-
2)	Vorschalldämpfer mit Katalysator / <i>presilencer with catalytic converter</i>	Originalteile / <i>original parts</i>	-
3)	Schalldämpfer / <i>silencer</i> (Austrittsrohr / <i>outlet pipe</i> Ø 32)	konisch / <i>conical</i> Ø 76,6 / 114 Länge ohne Endkappen / <i>length without endcaps</i> 260	M-HCUFG001 e26*08107*G E26 92R-01 8107

ANLAGE 2
ENCLOSURE 2

zum Prüfbericht Nr. / to test report no.
Typ / Type:
Hersteller / Manufacturer:

18-00030-CM-GBM-00
M-HCUFG001
Akrapovic, Malo Hudo 8a
1295 Ivančna Gorica, Slovenija

Verwendungsbereich (Fahrzeugdaten) / Field of application

Seite / Page 1/1

Lfd. Nr.	Hersteller	Fabrikmarke	Handelsbezeichnung	Fahrzeugtyp ab Genehmigung Nr.	Var. Vers.	Motortyp 4 Takt	Hubraum in cm ³	Nennleistung kW/min ⁻¹	Sonstige bestimmende Merkmale	Anordnung entspr. Anl. 1 lfd. Nr.
<i>No. of vehicle</i>	<i>Manufacturer</i>	<i>Trade mark</i>	<i>Commercial description</i>	<i>Vehicle type beginning with no. of homologation</i>	<i>Var. Vers.</i>	<i>Engine type 4 Stroke</i>	<i>Engine capacity in cm³</i>	<i>max. engine power kW/min⁻¹</i>	<i>Additional remarks</i>	<i>Composition reg. enclosure no. 1</i>
1)	KTM AG	Husqvarna	Svartpilen 401	HQV 401	alle	938	373	31/9000	mit Kat.*) / with cat.	1)2)3)
2)			Vitpilen 401	e1*168/2013*00064*	all	938	373	31/9000		

*) Die serienmäßigen Katalysatoren bleiben unverändert im Abgassystem. Eine Verschlechterung des Abgasverhaltens ist nicht zu erwarten. /
The original catalytic converter remains in the exhaust system. A degradation of catalyst efficiency is not expected.

ANLAGE 3
ENCLOSURE 3

zum Prüfbericht Nr. / to test report no.
Typ / Type:
Hersteller / Manufacturer:

18-00030-CM-GBM-00
M-HCUFG001
Akrapovic d.d.,
1295 Ivančna Gorica, Slovenija

Ergebnis der Prüfungen / Test results

Seite / Page 1/1

Lfd.Nr.	Leistung Serie kW/min ⁻¹	Leistung Austausch kW/min ⁻¹	Vmax Serie km/h	Vmax Aus- tausch km/h	Fahrgeräusche in dB(A) / Sound levels driving vehicle in dB(A)					Standgeräusche in dB(A) / Sound levels stationary vehicle in dB(A)			
					gemes- sen in Gang	Grenz- wert **)	Serie gemes- sen	Austausch gemessen	bei km/h	lt. Fzg. BE	Serie gemes- sen /	Austausch gemessen	bei min ⁻¹
No. of vehicle	Engine power original kW/min ⁻¹	Engine power non original kW/min ⁻¹	Vmax original km/h	Vmax non original km /h	measured in gear ratio	Limit Value **) SL _{EU4}	Original mea- sured L _{urban}	Non original measured L _{urban}	at km/h	Vehicle type hom.	Original mea- sured	Non original measured	at min ⁻¹
1) A*	31/9000	31/9000	-	-	3	77	77	76	50	85	87	87	4500

*) Versuchsreihe / test series

**) Grenzwert der Richtlinienfassung, die bei Erteilung der Fahrzeuggenehmigung Gültigkeit hatte /
Limit value of directive which was valid by vehicle type homologation

HUSQVARNA SVARTPILEN 401

STOCK EXHAUST

AKRAPOVIC SLIP-ON

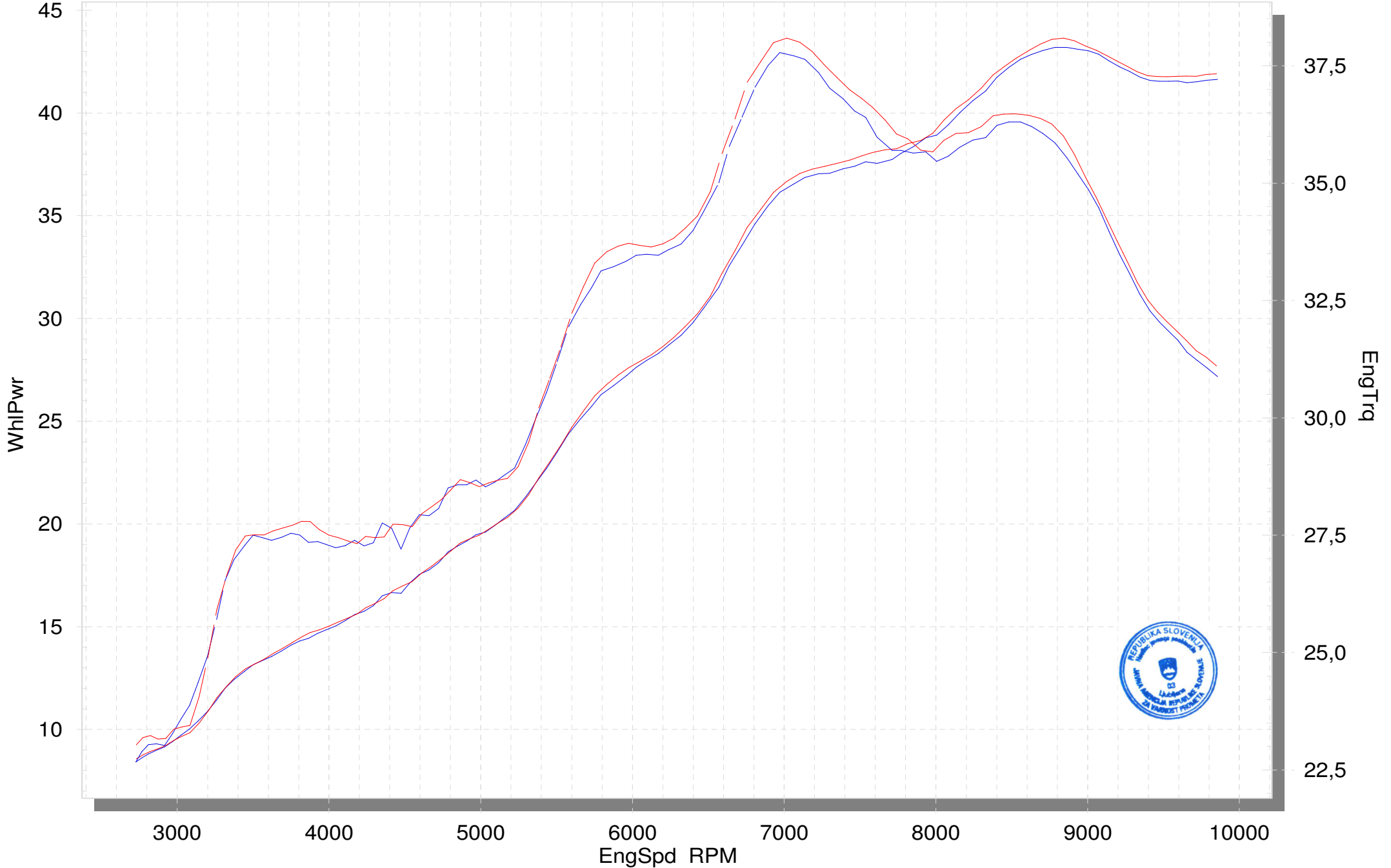

Test report no.: M170384038-041



Uniform provisions concerning the approval of vehicles of category L₃,
with regard to noise according to ECE-R 41.04, Annex 3

0. Customer

Company: Akrapovič d.d.
Address: Malo Hudo 8a
ZIP-Code/City/Country: 1295 Ivancna Gorica, Slovenia



1. Vehicle

Manufacturer: Husqvarna
Model / Trade name: 401 Svartpilen
Type: -
Variant / Version: -
Category, subcategory: L3e-A3
Vehicle Ident. No.: VBKUNJ409JM218496
Year of manufacture: 2017
Type App. No./EG/ECE: e1*168/2013*00064
Maximum vehicle speed: n.a. [km/h]
Milage: 39 [km]
Type approval stationary: 85 [dB(A)]
Type approval L_{urban}: 75 [dB(A)]

2. Engine

Manufacturer: KTM
Type: 7-398*27161*
Working principle: Positive ignition
Stroke numbers: 4-stroke
max. Power P_n: 31 [kW]
Engine speed S: 9000 [rpm]
Idle Engine speed: 1650 [rpm]
Cylinder numbers: 1
Cylinder capacity: 373 [cm³]
Engine position: FRONT

3. Transmission

Type: Manual
Ident. No.: n.a.
Numbers of axles: 2
Numbers of wheels: 2
Powerd axles: Axle 2
Number of gears: 6
Gear mode: Locked
Ratio Prim:Sek: 15 / 45
Driving mode: n.a.

4. Tyres

	front	rear
Manufacturer:	Pirelli	Pirelli
Type:	Scorpion Rally	Scorpion Rally
Dimension:	110/70 R17	150/60 R17
Infaltion pressure:	n.a.	n.a.

5. Exhaustsystem

	No.	Manufacturer	Marking left	Marking right
Pre Catalyst:				
Catalyst:	1	KTM		n.a.
Front sil.:				
Middle sil.:				
Rear sil.:	1	Akrapovic		CUFG-Shape
Tail pipe:	1	Akrapovic		Insert D=32mm

Test report no.: M170384038-041



**Uniform provisions concerning the approval of vehicles of category L3,
with regard to noise according to ECE-R 41.04, Annex 3**



6.0 Measurements and Calculation of the moving vehicle

6.1 Results pass by noise

Gear	Run	Mode	acc. point ⁽²⁾ [m]	A-A'		P-P'		B-B'		a _{wot test} [m/s ²]	a _{wot aver} [m/s ²]	Sound level L ⁽³⁾		L _{mode aver}		L _{mode max} [dB(A)]	L _{wot} ⁽⁴⁾ [dB(A)]	L _{crs} ⁽⁴⁾ [dB(A)]	L _{urban} [dB(A)]
				v [km/h]	n [rpm]	v [km/h]	n [rpm]	v [km/h]	n [rpm]			left [dB(A)]	right [dB(A)]	li [dB(A)]	re [dB(A)]				
3	21	wot ₍₃₎	0,0	40,3	4188	49,3	5045	57,6	5595	3,27	3,19	80,8	80,6	80,8	80,3	80,8	80,8	72,0	76,2
3	26			39,3	4192	49,5	5002	57,5	5551	3,40		81,0	80,2						
3	27			39,9	4189	49,5	5058	55,6	5451	2,89		80,5	80,2						
3	29	crs ₍₃₎		49,8	5027	49,6	4990	49,5	5000			71,8	72,1	71,8	72,0	72,0	80,8	72,0	76,2
3	30			49,8	5035	49,8	4976	49,4	4995			72,0	71,8						
3	31			50,0	5036	49,9	5045	49,9	5048			71,7	72,2						

2) Acceleration point according Line A-A'; 3) measurement values are given with the 1 dB(A) deduction; 4) Intermediate Results

6.2 Weights and Dimensions

max. perm. Weight:	355	[kg]
Kerb mass vehicle m _{kerb} :	155	[kg]
Testweight m _{ro} (incl. Rider):	230	[kg]
Reference length l _{ref} :	2,10	[m]
Power-to-Mass Ratio PMR:	134,8	

6.3 Constants/Factors

Reference acceleration a _{wot ref} :	2,93	[m/s ²]
lower limit Target acceleration a _{wot ref min} :	2,64	[m/s ²]
upper limit Target acceleration a _{wot ref max} :	3,22	[m/s ²]
Target acceleration a _{urban} :	1,54	[m/s ²]
Gear selected (i):	3	
Gear selected (i+1):	-	
Gear weighting factor k:	-	
Partial power factor k _p	0,520	

6.4 Vehicle speeds of measurements⁽⁵⁾

gear (i):		
Pre-acceleration length:	0,0	[m]
V _{PP} :	49,4	[km/h]
V _{BB} :	56,9	[km/h]
gear (i+1):		
Pre-acceleration length:	-	[m]
V _{PP} :	-	[km/h]
V _{BB} :	-	[km/h]

5) speed average of 3 runs

Test report no.: M170384038-041



Uniform provisions concerning the approval of vehicles of category L3,
with regard to noise according to ECE-R 41.04, Annex 3

7. Results stationary noise level

	Sound level L		Engine speed [rpm]
	left [dB(A)]	right [dB(A)]	
1. Run		86,9	4500
2. Run		86,6	
3. Run		86,1	
	86,9		

8. Measurement conditions

Air temperature:	5,0	[°C]
Surface temperature:	5,0	[°C]
Wind speed:	0,0	[m/s]
Wind direction:	318	[°]
Air humidity	84	[%]
Air pressure:	1013	[mbar]

9. General Requirements

Ambient noise level		
before Meas.:	39,90	[dB(A)]
after Meas.:	44,80	[dB(A)]
Calibration level (Target):	94,00	[dB(A)]
Calibration level Mikro 1:	94,00	[dB(A)]
Calibration level Mikro 2:	94,00	[dB(A)]

10. Summary Test Results

10.1 Noise levels of stationary vehicle

L: **87** [dB(A)]

10.2 Noise levels of moving vehicle

Intermediate result		Limit
L _{wot rep} :	80,8 [dB(A)]	82 [dB(A)]
L _{crs rep} :	72,0 [dB(A)]	
Final Result		
L _{urban} :	76 [dB(A)]	77 [dB(A)]

11. General

Expert:	Wibmer Christoph
Test driver:	Penca Gasper
Test track:	Akrapovic, Novo Mesto
Test date:	05.12.2017
FAKT-motion P-Nr.:	M17W-0384
Technical institute:	FAKT-motion GmbH, Junkersstr. 1, 87734 Benningen
Data file:	HUSQVARNA_401_SVARTPILEN_17_Akrapovic_HOM_UNECE_R41_04_Run.csv
Annex:	
Remarks:	



12. Summary

The vehicle meet the requirements of the regulation in the items ECE-R 41.04

Benningen, 19.12.2017

Place, Date of issue

Signature Expert

Information Document M-HCUFG001

relating to EU type-approval of a noise-abatement device as a STU

TÜV SÜD Auto Service Technical Report: 18-00030-CM-GBM-00

Item No.	(Sub) categories	Detailed information
B.		General information concerning systems, components or separate technical units
0.7.	L1e — L7e	Make(s) (trade name(s) of manufacturer): AKRAPOVIC Exhaust System Technology
0.8.	L1e — L7e	Type: M-HCUFG001
0.8.1.	L1e — L7e	Commercial name(s) (if available): n.a.
0.8.2.	L1e — L7e	Type-approval number(s) (if available): e26*134/2014*2016/1824G*08107*00
0.8.3.	L1e — L7e	Type-approval(s) issued on (date, if available): n.a.
0.9.	L1e — L7e	Company name and address of manufacturer: Akrapovic d.d. Malo Hudo 8a 1295 Ivančna Gorica Slovenia
0.9.1.	L1e — L7e	Name(s) and address(es) of assembly plants: n.a.
0.9.2.	L1e — L7e	Name and address of manufacturer's authorised representative, if any: n.a.
0.10.		Vehicle(s) for which the system/separate technical unit is intended for:
0.10.1.	L1e — L7e	Type: see Technical Report
0.10.2.	L1e — L7e	Variant: see Technical Report
0.10.3.	L1e — L7e	Version: see Technical Report
0.10.4.	L1e — L7e	Commercial name(s) (if available): see Technical Report
0.10.5.	L1e — L7e	Category, subcategory and sub-subcategory of vehicle : see Technical Report
C.		General information concerning vehicle, systems, components or separate technical units
0.12.		Conformity of production
0.12.1.	L1e — L7e	Controlled by ISO 9001:2008 Quality Management System certified by TÜV SÜD Management Service GmbH Registration no.: 12 100 31148 TMS
1.		GENERAL CONSTRUCTION CHARACTERISTICS
1.8.		Propulsion unit performance
1.8.1.	L3e, L4e, L5e, L7e-A, L7e-B2	Declared maximum vehicle speed: km/h see Technical Report
1.8.2.	L1e, L2e, L6e, L7e-B1, L7e-C	Maximum design vehicle speed : and gear in which it is reached: n.a.
1.8.3.	L1e — L7e	Maximum net power combustion engine: . kW at . min ⁻¹ at A/F ratio: see Technical Report
1.8.4.	L1e — L7e	Maximum net torque combustion engine: . Nm at . min ⁻¹ at A/F ratio: see Technical Report
1.8.5.	L1e — L7e	Maximum continuous-rated power electric motor (15/30 minutes power): n.a.
1.8.6.	L1e — L7e	Maximum continuous-rated torque electric motor: Nm at min ⁻¹ n.a.
1.8.7.	L1e — L7e	Maximum continuous total power for propulsion(s): kW. at ... min ⁻¹ at A/F ratio: n.a.
1.8.8.	L1e — L7e	Maximum continuous total torque for propulsion(s): Nm at min ⁻¹ at A/F ratio: n.a.
1.8.9.	L1e — L7e	Maximum peak power for propulsion(s): kW at min ⁻¹ at A/F ratio: n.a.
4.		GENERAL INFORMATION ON ENVIRONMENTAL AND PROPULSION UNIT PERFORMANCE
4.0		General information on environmental and propulsion performance
4.0.1.	L1e — L7e	Environmental step : Euro (4)
4.0.2.	L1e — L7e	Fuel consumption: see WVTA
4.0.3.	L1e — L7e	CO ₂ emissions: see WVTA
4.0.4.	L1e — L7e	Energy consumption: n.a.
4.0.5.	L1e — L7e	Electric range: n.a.
4.0.6.		Sound level
4.0.6.1.	L1e — L7e	Limit value for L _{urban} : see Technical Report
4.4.	L1e — L7e	Additional information on environmental and propulsion unit performance
4.4.4.	L1e — L7e	All additional technical information according to UN Regulation No. 92, are mentioned in the Technical Report or shown in the attachments.



Information Document M-HCUFG001

relating to EU type-approval of a noise-abatement device as a STU

TÜV SÜD Auto Service Technical Report: 18-00030-CM-GBM-00

Anlage <i>Enclosure</i>	Zeichnung Nr. <i>Drawing no.</i>	Datum <i>Date</i>	Seiten <i>Pages</i>
Zeichnung Schalldämpfer <i>Drawing silencer</i>	M-HCUFG001	20.02.2018	1
Stückliste <i>Part list</i>	M-HCUFG001	-	1
Zusammenstellungszeichnung <i>Assembly drawing</i>	Husqvarna Vitpilen/Svartpilen 401	-	2
Montageanleitung <i>Installation instructions</i>	285.05.999.000 Husqvarna Vitpilen/Svartpilen 401	01/2018	10

AKRABOVIČ, d.d.

Malò Hudo 8a, 1295 Ivančna Gorica,
Slovenija

Rosa Uroš, Managing Director

27.02.2018



This document is confidential and intended only for internal use and/or use by Akrapovič business partners. Any copying, distribution or use of this document, in part or as a whole, is prohibited, unless as permitted within the scope of the prior written consent.

Ta dokument je zaupne narave in namenjen interni uporabi in/ali uporabi s strani poslovnih partnerjev družbe Akrapovič. Dokumenta ter njegove vsebine ni dovoljeno na noben način, delno ali v celoti, kopirati, distribuirati ali uporabiti, razen v predhodno pisno dovoljene namene.

Revizija risbe/ Drawing revision	Polje/ Area	Opis spremembe/ Description of modification	Datum/ Date	Spremenil/ Modified by

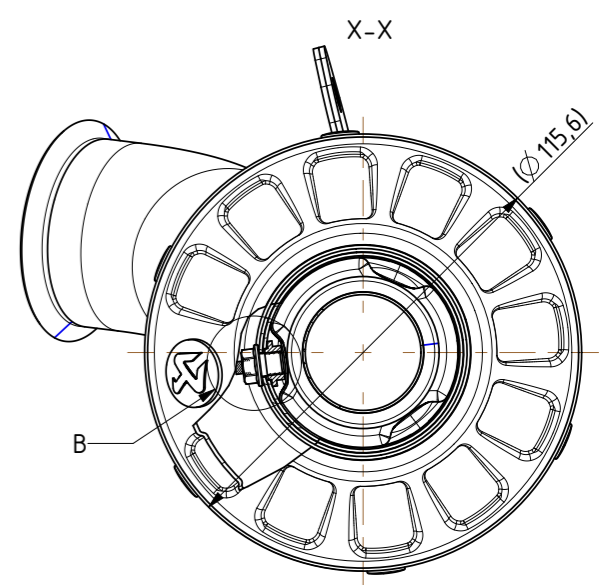
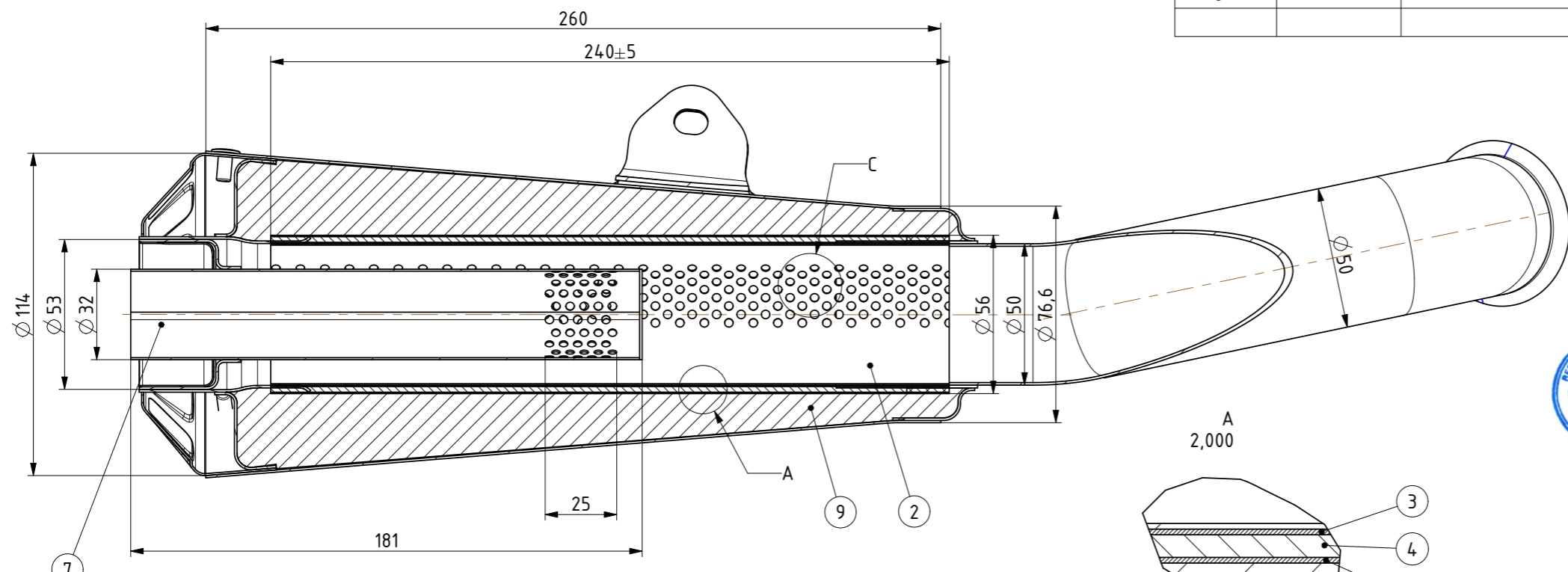

Tempered proof plug is pressed into the screw head. Screw is welded on the pipe.

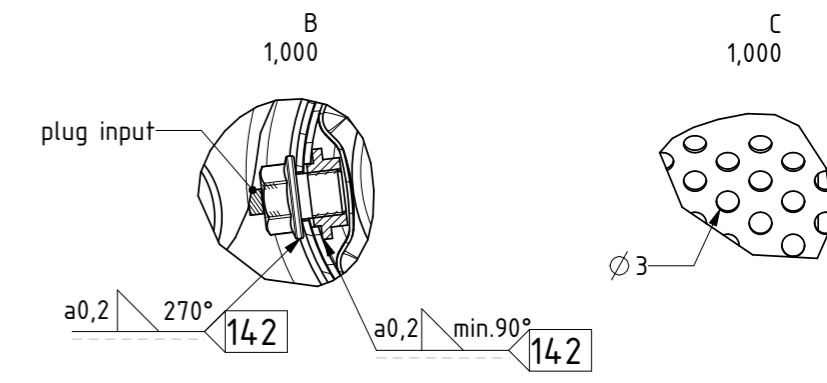
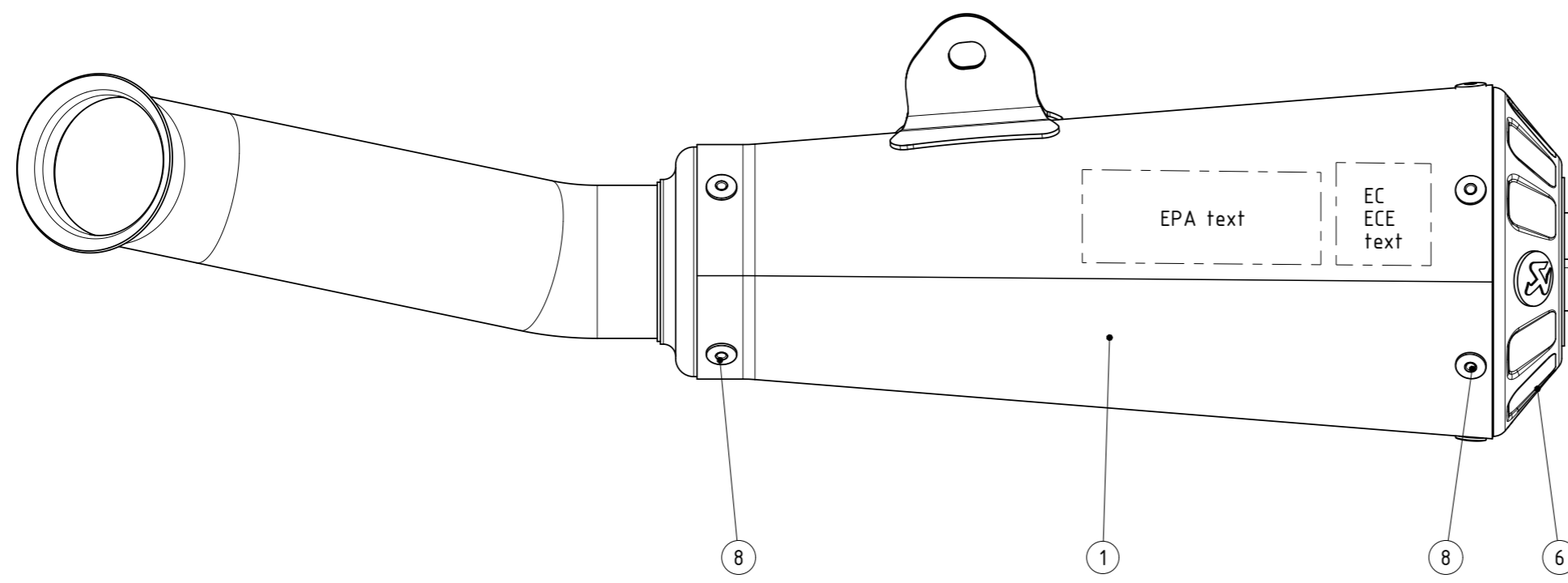

Okvir: 12x9mm
 Arial
 e: h=6mm
 26: h=3mm
 Krog: Ø 8mm
 Ariel Narrow
 E: h=4mm
 26: h= 2,7mm

Vstavi logotip L=20mm
 M-HCUFG001
 e26 08107 G
 E26 92R-01 8107

Logotip
 Arial H=3,5mm
 Arial H=3mm
 Arial H=2,7mm
 Velikost gravure:
 L=31mm H=32mm

Arial H=2,5mm
 Velikost gravure:
 L=75mm H=25mm

MOTORCYCLE EXHAUST SYSTEM NOISE EMISSION CONTROL INFORMATION: THIS KTM EXHAUST SYSTEM 285.05.999.000, MEETS EPA NOISE EMISSION REQUIREMENTS OF 80dB(A) FOR THE FOLLOWING MOTORCYCLES: HQV9380373. INSTALLATION OF THIS EXHAUST SYSTEM ON MOTORCYCLE MODELS NOT SPECIFIED MAY VIOLATE FEDERAL LAW.

Material:	SS	Datum/ Date:	20.02.2018	Ime/ Name:	Hafnar Roman	CAD okolje/ CAD system:	Creo Parametric 2,0																																									
Masa/ Mass:	3 [kg]	Konstruiral/ Made by:		Preveril/ Checked by:		ISO 128																																										
Tolerance prostih mer/ General tolerances	<table border="1"> <thead> <tr> <th rowspan="2">Tolerančni razred</th> <th colspan="6">Nominalne mere po ISO 2768-1</th> </tr> <tr> <th>do 6</th> <th>od 6 do 30</th> <th>od 30 do 120</th> <th>od 120 do 400</th> <th>od 400 do 1000</th> <th></th> </tr> </thead> <tbody> <tr> <td>f</td> <td>±0,05</td> <td>±0,1</td> <td>±0,15</td> <td>±0,2</td> <td>±0,3</td> <td></td> </tr> <tr> <td>M</td> <td>±0,1</td> <td>±0,2</td> <td>±0,3</td> <td>±0,5</td> <td>±0,8</td> <td></td> </tr> <tr> <td>C</td> <td>±0,2</td> <td>±0,5</td> <td>±0,8</td> <td>±1,2</td> <td>±2,0</td> <td></td> </tr> <tr> <td>V</td> <td>±0,5</td> <td>±1,0</td> <td>±1,5</td> <td>±2,5</td> <td>±4,0</td> <td></td> </tr> </tbody> </table>	Tolerančni razred	Nominalne mere po ISO 2768-1						do 6	od 6 do 30	od 30 do 120	od 120 do 400	od 400 do 1000		f	±0,05	±0,1	±0,15	±0,2	±0,3		M	±0,1	±0,2	±0,3	±0,5	±0,8		C	±0,2	±0,5	±0,8	±1,2	±2,0		V	±0,5	±1,0	±1,5	±2,5	±4,0		Potrdil/ Approved by:		Status risbe/ Drawing status:		Merilo/ Scale:	0,450
Tolerančni razred	Nominalne mere po ISO 2768-1																																															
	do 6	od 6 do 30	od 30 do 120	od 120 do 400	od 400 do 1000																																											
f	±0,05	±0,1	±0,15	±0,2	±0,3																																											
M	±0,1	±0,2	±0,3	±0,5	±0,8																																											
C	±0,2	±0,5	±0,8	±1,2	±2,0																																											
V	±0,5	±1,0	±1,5	±2,5	±4,0																																											
Toplotna obdelava/ Heat treatment		Opis/ Description:	M-HCUFG001 - Husqvarna Vitpilen/Svartpilen 401		Format risbe/ Drawing format:	A3																																										
Povrsinska obdelava/ Surface treatment	3,2	Pomembnost karakteristike/ Importance of dimension:			Informativna dimenzija/ Optional dimension:	()																																										
ISO 1302		NA RAZ 063			Št. lista/ Sheet no.:	1	Št. listov/no. of sheets:	1																																								
Posnetje neoznacjenih robov/ Edges of undefined shape:		ISO 13715	SAP:		Revizija risbe/ Drawing revision:	0																																										

HU VitpilenSvartpilen 401 part list M-HCUFG001

Poz.	Component	Dim. / Weight	Pcs.	Material
1	Outer sleeve	Ø115,6/Ø76,6 × 260	1	SS
2	Tube perforated (5xØ3/cm ²)	Ø50x240	1	SS
3	Fine mesh	240x176	1	AISI 304
4	Damping material SS	50g	1	SS
5	Fine mesh	240x176	1	AISI 304
6	End cap	Ø114x48	1	SS
7	Restrictor	181xØ32/53 (100 holes Ø3)	1	SS
8	Rivet	Ø4,8x8	10	SS
9	Damping material - glass wool	Road trak 300 - 265g	1	E glass





Original Parts
with Catalytic Converter

M-HCUFG001
e26*08107*G
E26 92R-01 8107

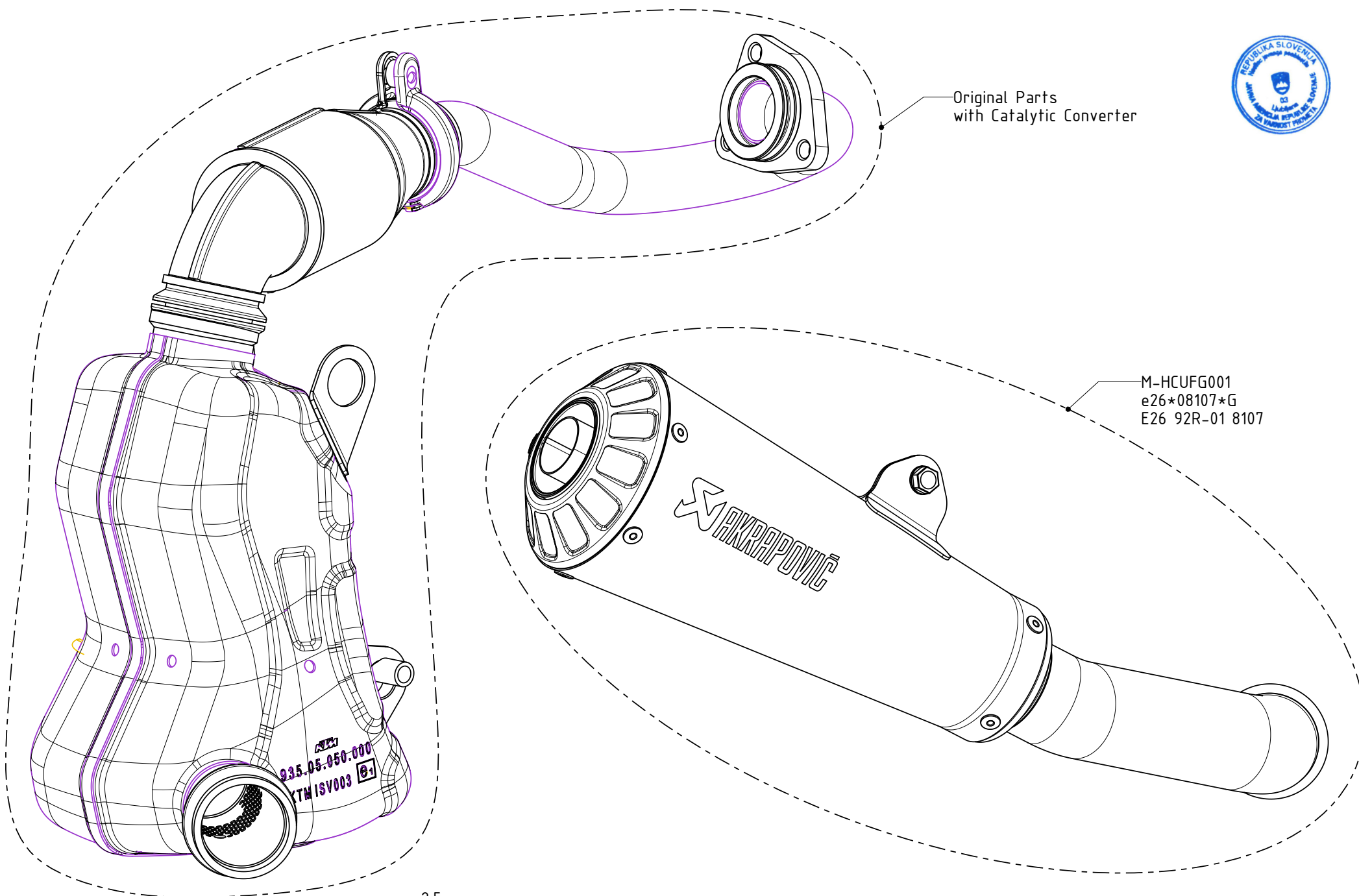

Husqvarna Vitpilen/Svartpilen 401 Slip-ON / EC / ECE Type approval

Product code: S-HU4SO1-HCUFGSSBL

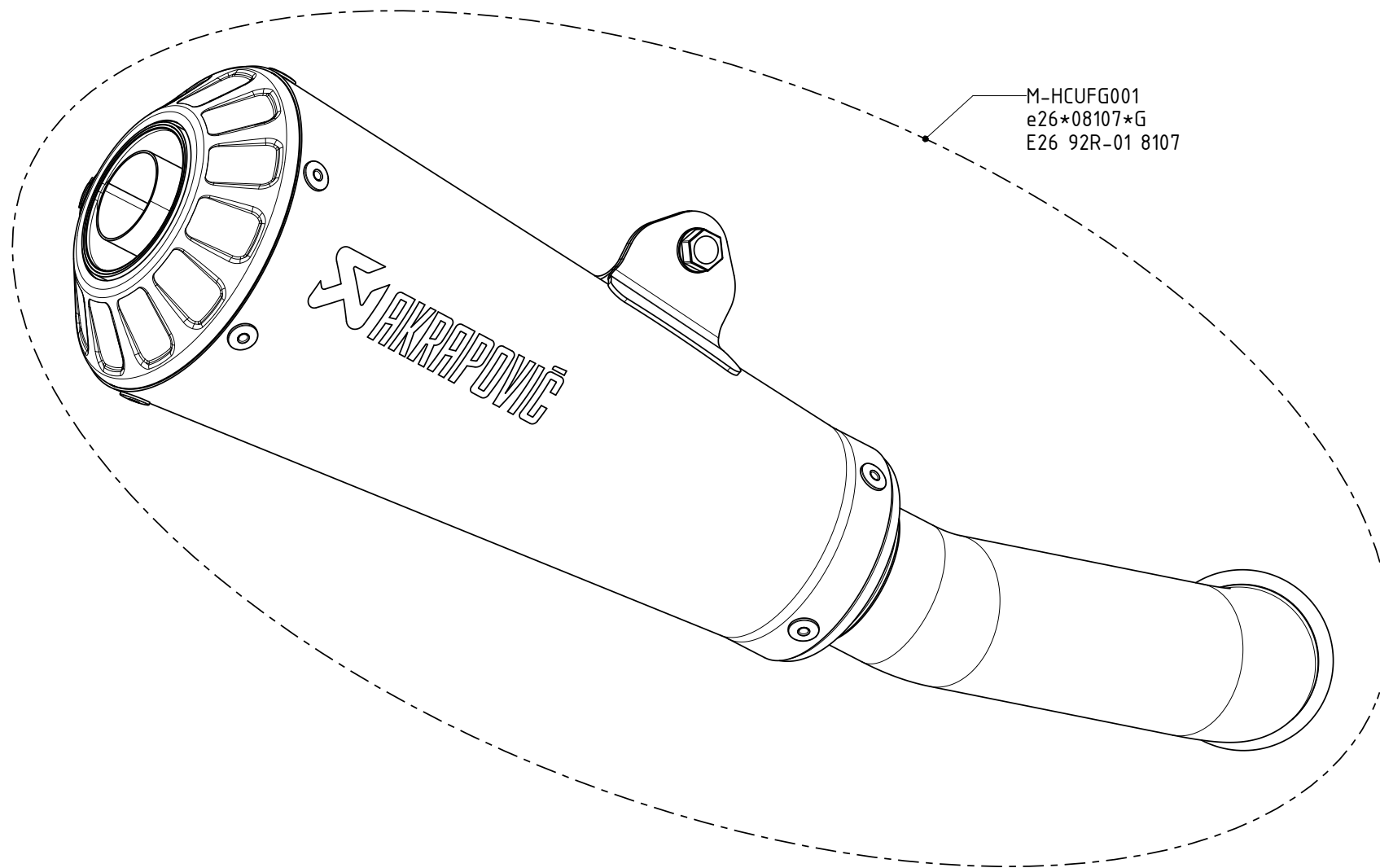



Installation instructions

Akrapovič Exhaust System

Slip-On Line

285.05.999.000

Husqvarna Vitpilen/Svartpilen 401



506400

EN

Revision 1.0 02/2018



www.akrapovic.com

Congratulations on purchasing the Akrapovič exhaust system. The Akrapovič exhaust system is a product of Akrapovič d.d., Malo Hudo 8a, 1295 Ivančna Gorica, Slovenia ("Akrapovič").

Please read this entire installation manual carefully prior to installing and using the Akrapovič exhaust system.

Akrapovič exhaust system should only be installed by persons skilled in motorcycle exhaust system installation and performance. The instructions provided in this manual should be followed to ensure proper installation and safe use of the Akrapovič exhaust system. Akrapovič and/or its partners shall not be held liable for any damage or personal injury (including direct, indirect, or consequential damage) sustained as a result of improper installation of the Akrapovič exhaust system or its use and maintenance contrary to the instructions and warnings contained herein.

If you have any questions regarding the installation and/or proper use of the Akrapovič exhaust system or this manual, please contact your local Akrapovič partner.

GENERAL INFORMATION

Your safety is our number one priority. Please ride your motorcycle responsibly, safely and always obey local traffic rules.

All statements made with regard to the exhaust system's compliance are made in respect of the exhaust system "as is". Any modifications of the Akrapovič exhaust system or its improper installation, use or maintenance that is not in accordance with this Installation manual, may result in severe damage to the exhaust system and/ or engine, as well as personal injury, and may affect the exhaust system's compliance with the legal requirements, such as exhaust system's air and/ or noise emissions (as an example, the motorcycle may not be suitable for use on public roads any longer).

The exhaust system may only be used in accordance with relevant laws and regulations, including state and federal, where applicable.

Technical specifications of Akrapovič exhaust systems and related products are subject to change without notice.

COPYRIGHT AND OTHER RIGHTS NOTICE

The Akrapovič trademark, including corporate logos and emblems, are subject to copyright as well as trademark rights of Akrapovič, its licensors, or third persons authorizing Akrapovič to use them.

Any reproduction, technical or other manipulation, translation, or other use of the copyright and/or trademark rights contained herein is prohibited without the explicit prior written consent of Akrapovič. The same especially applies to the entire contents of this manual and/or any of its parts, including but not limited to technical specifications, instructions, graphs, photographs, and so on included in this manual.

Akrapovič takes all copyright and other rights infringement cases under serious consideration. If you have any reason to believe that your exhaust system is not an original Akrapovič product, please contact our local partners or Akrapovič at info@akrapovic.com.



SAFETY AND COMPLIANCE WARNING, PLEASE READ CAREFULLY

BEFORE REMOVING THE STOCK EXHAUST SYSTEM AND BEGINNING THE INSTALLATION OF YOUR NEW AKRAPOVIČ EXHAUST, PLEASE MAKE SURE THAT ALL ITEMS LISTED BELOW ARE VERIFIED:

- THIS MANUAL IS SPECIFIC TO THE MOTORCYCLE INDICATED ON THE COVER PAGE, FOR WHICH IT IS DESIGNED. INSTALLATION PROCEDURES VARY DEPENDING ON THE TYPE OF MOTORCYCLE. PLEASE VERIFY THAT THE AKRAPOVIČ **EXHAUST SYSTEM AND THIS INSTALLATION MANUAL CORRESPOND TO THE TYPE OF YOUR MOTORCYCLE.**
- THE EXHAUST SYSTEM CAN GET EXTREMELY HOT DURING AND AFTER IT IS USED. MAKE SURE NOT TO TOUCH THE EXHAUST SYSTEM UNTIL IT IS COMPLETELY COOL. **ALLOW THE EXHAUST AND ENGINE TO COOL DOWN BEFORE BEGINNING INSTALLATION OR ANY OTHER WORK ON THE EXHAUST SYSTEM.**
- MAKE SURE THE MOTORCYCLE IS **SECURELY POSITIONED TO PREVENT TIPPING OVER** AND DAMAGE TO YOURSELF AND OTHERS, OR THE MOTORCYCLE.
- PLEASE MAKE SURE THAT YOU HAVE **ALL THE PARTS NECESSARY FOR THE INSTALLATION** OF YOUR NEW AKRAPOVIČ EXHAUST SYSTEM, SEE PARTS LIST ON PAGE 5. IF ANY OF THE PARTS IS MISSING, PLEASE DO NOT PROCEED WITH UNINSTALLING YOUR STOCK EXHAUST SYSTEM/ INSTALLING THE AKRAPOVIČ EXHAUST SYSTEM AND CONTACT THE RETAILER WHERE YOU PURCHASED THE AKRAPOVIČ EXHAUST SYSTEM.
- ALWAYS **SECURE YOUR MOTORCYCLE'S GROUND CLEARANCE.** FOR ADVANCED USERS, WE RECOMMEND YOU CHECK THE MOTORCYCLE SPRING PRELOAD SETTINGS TO OPTIMIZE GROUND CLEARANCE WHERE POSSIBLE.
- EVERY EXHAUST SYSTEM MUFFLER HAS ITS UNIQUE SERIAL NUMBER, WHICH IDENTIFIES THE AUTHENTICITY OF THE PRODUCT. YOU CAN FIND THE SERIAL NUMBER ON THE MUFFLER'S INLET PIPE. PLEASE REFER TO THE PICTURE BELOW. PLEASE VERIFY THAT YOUR EXHAUST SYSTEM IS AN ORIGINAL AKRAPOVIČ PRODUCT. IF YOU HAVE ANY DOUBTS, PLEASE CONTACT THE RESELLER WHERE YOU PURCHASED THE EXHAUST SYSTEM.

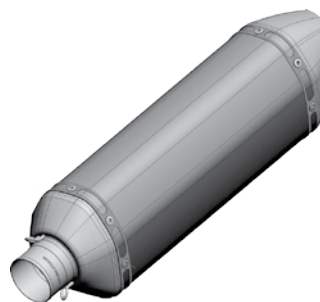
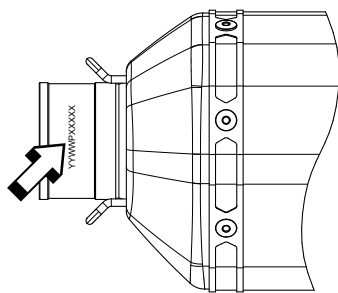

SERIAL NUMBER POSITION



NOISE AND EMISSION WARNINGS

General warning

Because of the world-wide distribution of Akrapovič d.d. products, neither Akrapovič d.d. nor any of its subsidiaries make any representation that the products comply with the air and/or noise emissions laws, or labeling laws, of any jurisdiction. The purchasers are entirely responsible for informing themselves of the applicable laws where the products are to be used and to comply with those law.

USA WARNING

Various U.S. states and the U.S. federal government have individual laws regulating the use of aftermarket exhaust parts and systems, especially as those parts and systems modify, remove, or replace original equipment catalyts. Please consult the appropriate laws in your area before installing any aftermarket part or system on your vehicle to ensure compliance with all applicable laws. Neither Akrapovic d.d. nor any of their subsidiaries or the sellers of the parts or systems make any representation that any of their parts or systems comply with any such laws.

CALIFORNIA WARNING

California laws prohibit the use of any aftermarket exhaust part or system that modifies, removes or replaces original equipment catalyts unless the California Air Resources Board has issued an Executive Order regarding such part or system or unless the part or system is exempted by being used only on racing vehicles on closed courses. Neither Akrapovic d.d. nor any of their subsidiaries make any representation that any of their parts or systems has received such an Executive Order or that any of their parts or systems conform with the racing vehicles exemption. The purchasers are entirely responsible for informing themselves of applicable California laws and to comply with those laws.

GENERAL NOTE

Photographs and other illustrations in this manual are symbolic and are intended to help represent individual steps for proper installation and use, as well as for a general overview. The actual component parts of the Akrapovič exhaust system may not entirely correspond to the photographs and other illustrations.

SYMBOLS

The following symbols are used throughout these installation instructions:



TOOLS AND PROTECTIVE EQUIPMENT REQUIRED



TIGHTENING TORQUE



LUBRICATION



HAND TIGHTEN



INSTALLATION TIP



CAUTION OR IMPORTANT

USE BOLT SEALANT



Apply 3 to 4 small drops of bolt sealant onto the cleaned and degreased threads before tightening the bolts.

WARNING! Avoid contact with skin, eyes and mucous membranes. Do not inhale fumes. Keep out of reach of children.

USE ANTI-SEIZE LEAD-FREE COPPER PASTE (black tube)



Provides trouble-free and long-lasting protection against seizing, corrosion and rusting of bolts, threaded ends, nuts, joints, etc. Also protects against vibration, wear and impact.

WARNING! Avoid eye contact. Keep out of reach of children.

USE ANTI-SEIZING GREASE (white tube)



Prevents seizing, corrosion and excessive wear between the titanium components of your exhaust system.

WARNING! Avoid eye contact. Keep out of reach of children.



Tools & equipment

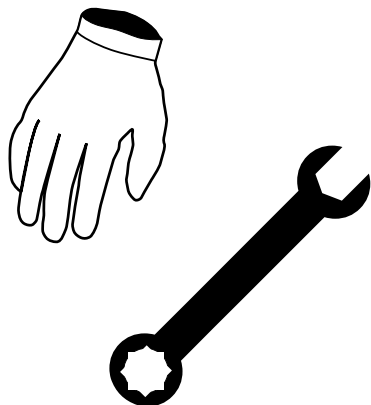

- T-handle Torx 45 wrench
- Combination 17 mm wrench
- T-handle 6 mm hexagon wrench

PARTS LIST

The following parts should be found in the box:

- Installation Manual
- Homologation certificate/ compliance documents if applicable
- Fitting material
- Muffler and/or pipes
- Parts depicted on schematic view

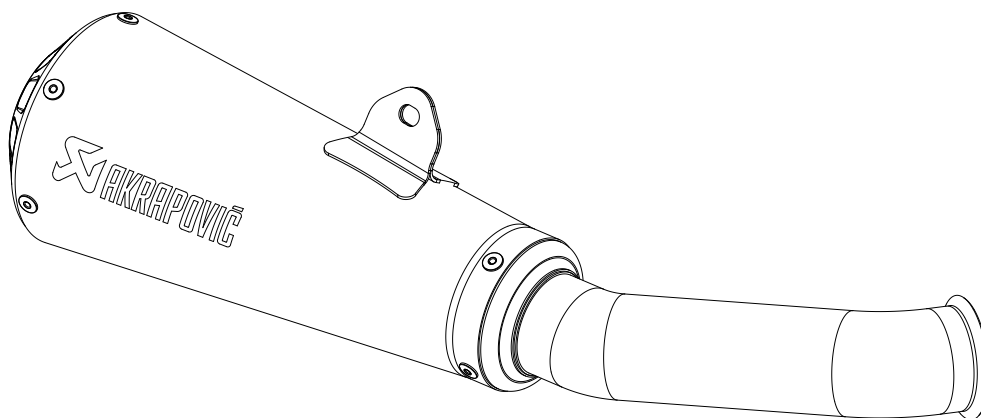

REMOVAL OF STOCK EXHAUST SYSTEM:

The process of uninstalling the original exhaust system may vary depending on the existing exhaust system. Please follow the original exhaust system manufacturer's instructions for uninstalling the original exhaust system.

If you for any reason decide otherwise, please note that any information provided in this respect herein should be considered as general information provided for your convenience only.

In case your Akrapovič exhaust system may not be used on certain roads or under certain conditions, please keep the stock or other exhaust system that you can use in such circumstances legally.

REMOVAL OF STOCK EXHAUST SYSTEM:

1. Put the motorcycle on a stand, we recommend a central racing stand. Make sure, that surface is solid and flat.
2. Unscrew the marked muffler's bracket bolt, marked clamp, and carefully remove the muffler off the motorcycle (**F 01**).

! CAUTION: be careful not to injure yourself or damage any part of the motorcycle during this procedure!



F 01

INSTALLATION OF THE AKRAPOVIČ EXHAUST SYSTEM:

1. Position the muffler correctly and hand tighten it onto the motorcycle and outlet side of the stock pre-muffler using bolt, nut and washer from the Akrapovič installation kit and stock clamp. Align the muffler in respect to the motorcycle and tighten the muffler's bracket bolt and clamp to the specified torques (**F 02, 03, 04**).

! CAUTION: be careful not to injure yourself or damage any part of the motorcycle during this procedure!



F 02



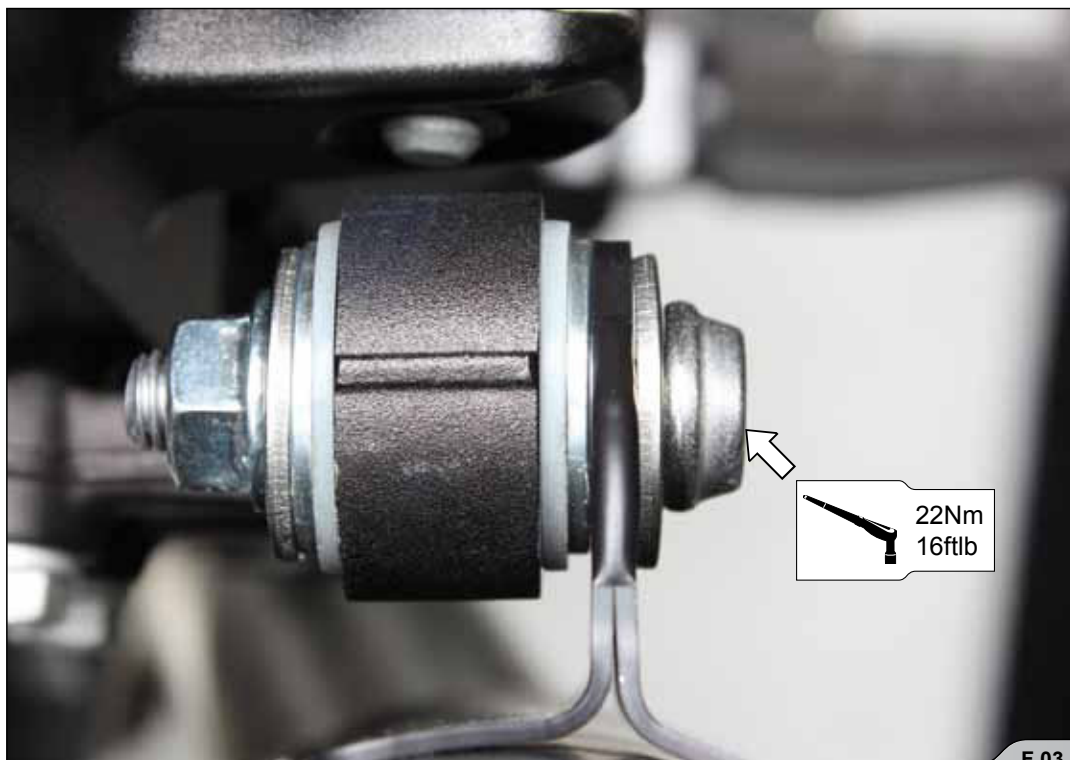

F 03



F 04



FINAL INSTALLATION AND MAINTENANCE:

Clean grease spots off all exhaust system surfaces, when installation is finished. Cleaning will prevent spots from burning onto the surface. Do not use aggressive chemical cleaners, because they can damage the surface or sticker.

1. Muffler – titanium outer sleeve: use a soft cloth sprayed with a multi-purpose spray lubricant (WD-40® or equivalent)*.
2. Muffler – carbon-fiber outer sleeve: use a soft dry cloth sprayed with all purpose foam cleaner, then wipe with a soft dry cloth.
3. Muffler – carbon-fiber outlet cap: use a soft dry cloth sprayed with all purpose foam cleaner, then wipe with a soft dry cloth.
4. Painted mufflers and parts – use a soft cloth sprayed with all purpose foam cleaner, then wipe with a soft dry cloth.
5. Chrome plated mufflers and parts: use a soft cloth sprayed with all purpose foam cleaner, then wipe with a soft dry cloth.
6. Stainless steel pipes: use a soft cloth sprayed with a contact cleaner, then wipe with a soft dry cloth.
7. Titanium pipes: use a soft cloth sprayed with a multi-purpose spray lubricant (WD-40® or equivalent)*.

*WD-40® is a trademark of the WD-40 Company.

Periodically make sure all the bolts and springs are sufficiently tight.



IMPORTANT: make sure all the bolts are sufficiently tightened. In case the exhaust system touches the cowling or other parts repeat the adjustment of the exhaust system or contact your authorized dealer!



CAUTION: after running engine for 30 minutes, retighten the bolts of the Akrapovič carbon-fiber heat shield!



INSTALLATION TIP: IT IS NORMAL IF WHITE SMOKE COMES OUT OF THE MUFFLER DURING THE FIRST 100 KM AFTER REPLACEMENT.



INSTALLATION TIP: A CHANGE IN THE COLOR OF THE EXHAUST SYSTEM IS NORMAL DUE TO THE HIGH TEMPERATURES.



CAUTION: DO NOT STAND BEHIND THE MUFFLER AT ANY TIME.



IMPORTANT: DO NOT USE AUTOMOTIVE WHEEL CLEANERS OR ANY CLEANING PRODUCTS WHICH CONTAIN ACIDIC ADDITIVES TO CLEAN AKRAPOVIČ EXHAUST SYSTEMS.



TROUBLESHOOTING:

Problem	Possible cause	Solution
Exhaust gas leaks out of the muffler/pipe connection	the rubber seal is damaged	replace the rubber seal



